



Two Button Buzzer Circuit



Provided by TryEngineering - www.tryengineering.org
[Click here to provide feedback on this lesson.](#)

Lesson Focus

Demonstrate how two switches interact in an electrical circuit such as that used to sound a buzzer. Note: This lesson plan is designed for classroom use only, with supervision by a teacher familiar with electrical and electronic concepts.

Lesson Synopsis

The Two Button Buzzer Circuit activity explores an everyday situation, where either of two or more buttons can ring a buzzer. Students learn how this type of circuit is structured, draw a schematic for it, and construct a two button buzzer model out of wires, a battery, buttons (switches), and a buzzer.

Age Levels

8-14.

Objectives

- ✦ Learn how switches control the flow of electricity.
- ✦ Learn to draw basic wiring diagrams.
- ✦ Learn how the electric circuit in a two button buzzer operates.
- ✦ Learn about teamwork and working in groups.

Anticipated Learner Outcomes

As a result of this activity, students should develop an understanding of:

- ✦ switches
- ✦ circuits and current
- ✦ basic electrical diagrams
- ✦ making and testing predictions
- ✦ teamwork

Lesson Activities

Students learn how two buttons (switches) can control a buzzer. Student groups then draw a schematic of a two button buzzer circuit and build a model of the circuit using wires, a battery, buttons (switches) and a buzzer. Final schematics are shared with other groups, with results and findings discussed as a class.

Resources/Materials

- ✦ Teacher Resource Documents (attached)
- ✦ Student Worksheets (attached)
- ✦ Student Resource Sheets (attached)

Alignment to Curriculum Frameworks

See attached curriculum alignment sheet.

Internet Connections

- ✦ TryEngineering (www.tryengineering.org)
- ✦ ITEA Standards for Technological Literacy: Content for the Study of Technology (www.iteaconnect.org/TAA)
- ✦ National Science Education Standards (www.nsta.org/standards)

Recommended Reading

- ✦ Buzz Off! Build Your Own Electronic Doorbell (Troll Assoc., ISBN: 0816761965)
- ✦ DK Eyewitness Series: Electricity (ISBN: 0751361321)
- ✦ Eyewitness Electricity, by Steve Parker (DK Publishing, ISBN: 0789455773)
- ✦ How Science Works, by Judith Hann (Readers Digest, ISBN: 0762102497)

Optional Writing Activity

- ✦ Write an essay or a paragraph describing other examples of two buttons (switches) operating an electrical device (garage door, stairway light, computer plugged into a power strip). How do these circuits differ from the buzzer example?

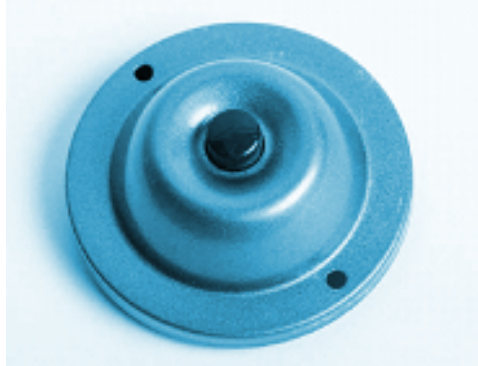

Two Button Buzzer Circuit

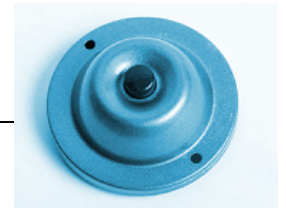

For Teachers:

Alignment to Curriculum Frameworks

Note: All Lesson Plans in this series are aligned to the National Science Education Standards which were produced by the National Research Council and endorsed by the National Science Teachers Association, and if applicable, also to the International Technology Education Association's Standards for Technological Literacy or the National Council of Teachers of Mathematics' Principles and Standards for School Mathematics.

◆ National Science Education Standards Grades K-4 (ages 4 - 9)

CONTENT STANDARD A: Science as Inquiry

As a result of activities, all students should develop

- ✦ Abilities necessary to do scientific inquiry
- ✦ Understanding about scientific inquiry

CONTENT STANDARD B: Physical Science

As a result of the activities, all students should develop an understanding of

- ✦ Light, heat, electricity, and magnetism

CONTENT STANDARD E: Science and Technology

As a result of activities, all students should develop

- ✦ Understanding about science and technology

◆ National Science Education Standards Grades 5-8 (ages 10 - 14)

CONTENT STANDARD A: Science as Inquiry

As a result of activities, all students should develop

- ✦ Abilities necessary to do scientific inquiry
- ✦ Understandings about scientific inquiry

CONTENT STANDARD B: Physical Science

As a result of their activities, all students should develop an understanding of

- ✦ Transfer of energy

CONTENT STANDARD E: Science and Technology

As a result of activities, all students should develop

- ✦ Understandings about science and technology

◆ Standards for Technological Literacy - All Ages

Design

- ✦ Standard 8: Students will develop an understanding of the attributes of design.
- ✦ Standard 9: Students will develop an understanding of engineering design.
- ✦ Standard 10: Students will develop an understanding of the role of troubleshooting, research and development, invention and innovation, and experimentation in problem solving.

Two Button Buzzer Circuit

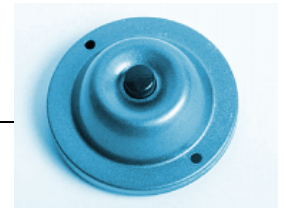

For Teachers: Teacher Resources

◆ Lesson Goal

Students learn how a two button buzzer circuit is structured, draw a schematic for it, and construct a model out of wires, a battery, buttons (switches), and a buzzer.

◆ Lesson Objectives

- ✦ Students learn how switches control the flow of electricity.
- ✦ Students learn to draw basic wiring diagrams.
- ✦ Students learn to predict outcomes and draw conclusions.
- ✦ Students learn about teamwork and working in groups.

◆ Materials

- Student Reference Sheets
- Student Worksheet
- One set of the following items for each group of students, consisting of:
 - 1 D size Battery
 - battery holder
 - Bell wire
 - Two button switches
 - Buzzer

◆ Procedure

1. Provide Student Reference sheets to students as advance reading material.
2. Have one set-up already prepared as an example.
3. Divide students into groups of 3-4 students.
4. Discuss how a doorbell works with students.
5. Ask students to draw a schematic diagram of the two button buzzer setup on the Student Worksheet.
6. Have each student group build a model of the buzzer circuit using provided materials (wire, battery, two buttons (switches), and buzzer).
7. Ask students to complete the student worksheet.
8. Each student group presents their schematics and buzzer circuit to the class, and discusses differences.

◆ Time Needed

1-2 class periods

◆ Suggestions

- Teacher may want to assign the Student Reference Sheet as advance reading homework.

Two Button Buzzer Circuit

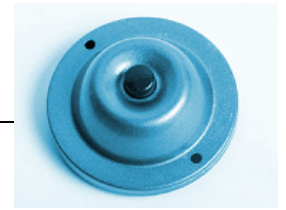

Student Resource: What is a Simple Circuit?

◆ Simple Circuit

A simple circuit consists of three elements: a source of electricity (battery), a path or conductor on which electricity flows (wire) and an electrical resistor (lamp) which is any device that requires electricity to operate. The illustration below shows a simple circuit containing a battery, two wires and a low voltage light bulb. The flow of electricity is caused by excess electrons on the negative end of the battery flowing toward the positive end, or terminal, of the battery. When the simple circuit is complete, electrons flow from the negative terminal through the wire conductor, then through the bulb (lighting it up), and finally back to the positive terminal - in a continual flow.

Simple Circuit

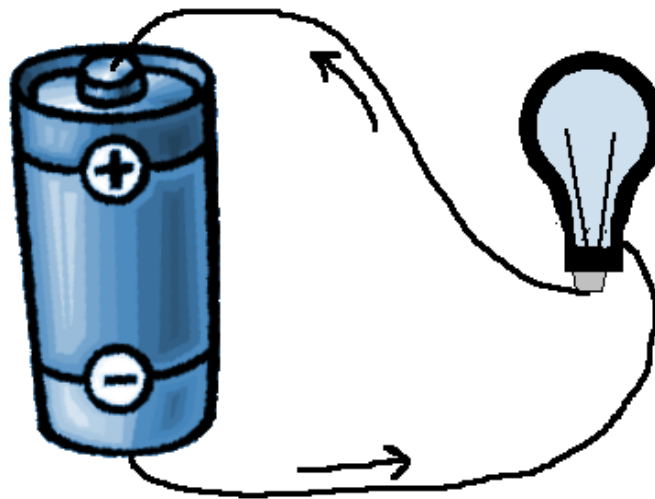

◆ Schematic Diagram of a Simple Circuit with Switch

The following is a schematic diagram of a simple circuit showing the electronic symbols for a battery, switch, and bulb.

Schematic Diagram of a Simple Circuit

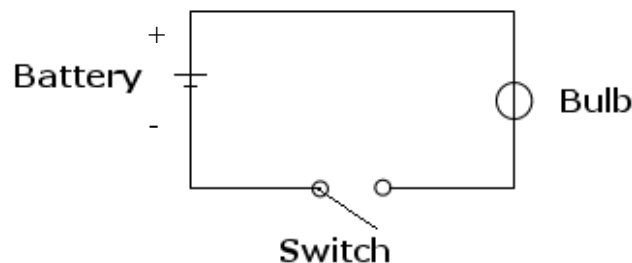

Two Button Buzzer Circuit

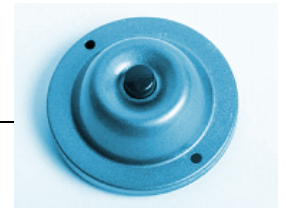

Student Resource: Simulating a Switch

◆ Simulating a Switch by Disconnecting a Wire or Adding a Pencil

There are several ways you can simulate a switch in a simple circuit. Simply removing and replacing the wire from the bulb can serve as a switch. Another simple switch can be made by attaching the end of one of the wires to the eraser end of a pencil using a rubber band. Then attach another rubber band to the other end of the pencil, and by simply laying the other end on top of - and then off of - the connecting wire, you have created a switch. Other types of conductors can also be used in switch design, such as aluminum foil, hairclips, paperclips, paper fasteners, and some metal pens.

Simulating a Simple Switch by Removing the Wire

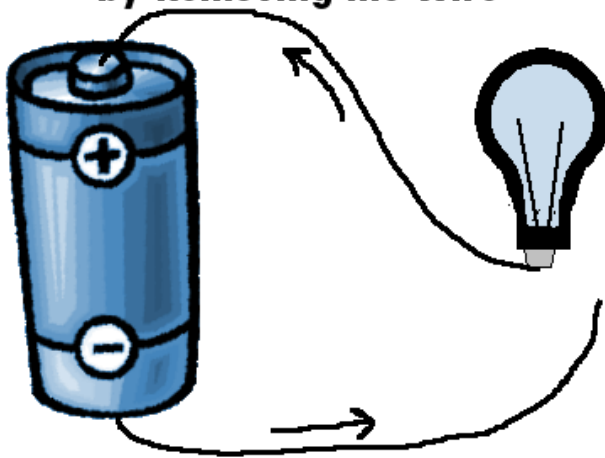

Using a Pencil to Create a Simple Switch

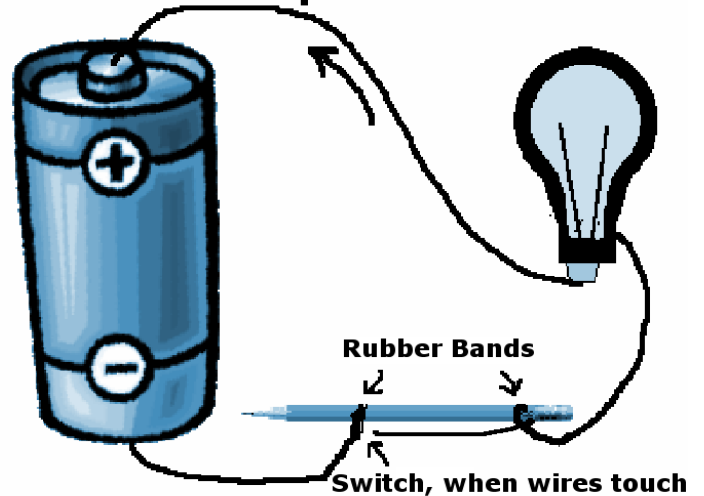

Schematic Diagram of a Simple Circuit

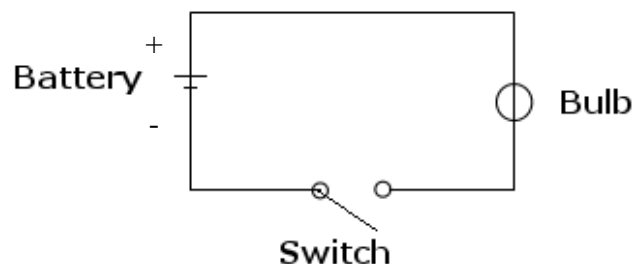

Two Button Buzzer Circuit

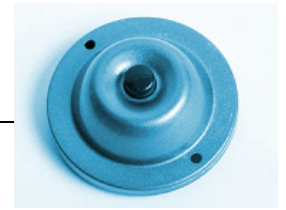

Student Resource:

◆ Buzzer Basics

The following diagram shows how two buttons (switches) can each be used to ring a buzzer. In this example, either button can control the buzzer. By pushing either button, the circuit is completed and the flow of electricity moves from the power source (battery) to the buzzer. It does not matter which button (switch) is activated.

Two Button Buzzer Simulation

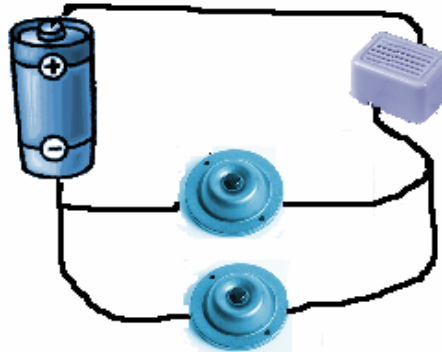

The schematic below shows how the buzzer circuit would operate.

Two Button Buzzer Schematic

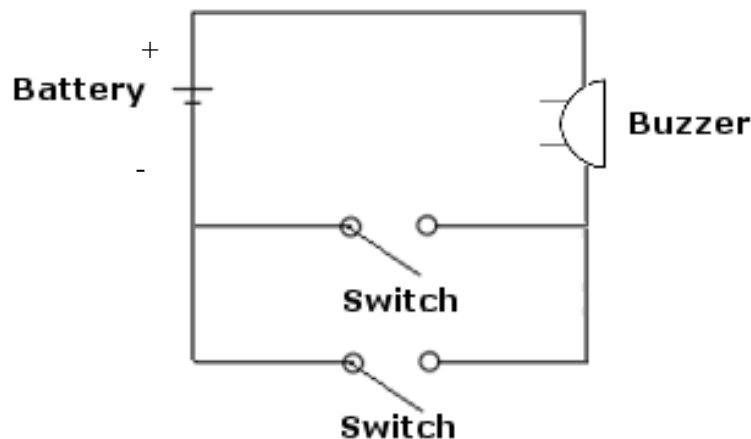

Two Button Buzzer Circuit

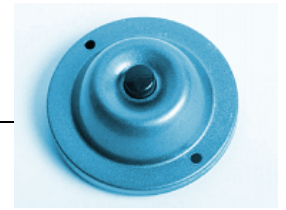

Student Worksheet:

◆ You are the Engineering Team!

Working as a team, you need to develop a two button buzzer circuit that would simulate how doorbells on either a front and back door could both ring a buzzer or doorbell.

1. Read the Student Reference sheets provided to your team.
2. Draw a schematic diagram of the two button buzzer setup below.
3. Once your team has a viable diagram, construct your circuit with the parts provided by your teacher (wire, battery, two buttons (switches), and buzzer).
4. Answer the questions which follow on this student worksheet.
5. Presents your group's design to the class after construction.

◆ Draw a schematic of the two button buzzer circuit design in the box below.

◆ Would there be a limit to the number of switches you could wire together to cause the buzzer to sound? If yes, why? If no, why not?

◆ Would this same circuit concept work for a garage door opener with two buttons (one in the car and one in the garage)? Why? Why not?

Advanced idea -- build a two button buzzer circuit that reaches from one classroom to the next!