

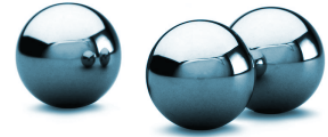

Getting Your Bearings



Provided by TryEngineering - www.tryengineering.org

Lesson Focus

Lesson focuses on the concept of friction and the use of ball bearings to reduce friction.

Lesson Synopsis

The Getting Your Bearings activity explores the concept of friction and shows how ball bearings reduce friction. Students learn about different uses for ball bearings, how the design has changed over time to incorporate roller bearings, test friction using marbles, and identify the use of ball bearings in everyday items.

Age Levels

8-18.

Objectives

- ✦ Learn about friction.
- ✦ Learn about ball bearings.
- ✦ Learn how engineers improved ball bearings and the development of roller bearings.
- ✦ Learn how roller/ball bearings are used in machines and impact everyday life.
- ✦ Learn about teamwork and problem solving in groups.

Anticipated Learner Outcomes

As a result of this activity, students should develop an understanding of:

- ✦ friction
- ✦ ball bearings
- ✦ engineering design
- ✦ problem solving
- ✦ teamwork

Lesson Activities

Students learn about friction and how ball bearings reduce friction and extend the life of machines. Topics examined include friction, ball bearings, engineering design, and problem solving. Students work in teams using marbles to simulate ball bearings.

Resources/Materials

- ✦ Teacher Resource Documents (attached)
- ✦ Student Resource Sheet (attached)
- ✦ Student Worksheets (attached)

Alignment to Curriculum Frameworks

See attached curriculum alignment sheet.

Internet Connections

- ✦ TryEngineering (www.tryengineering.org)
- ✦ Timken - Types of Antifriction Bearings (www.timken.com/AntiFriction/player.html)
- ✦ Bearings 101 (www.bearings.machinedesign.com/BDEList.aspx)
- ✦ ITEA Standards for Technological Literacy: Content for the Study of Technology (www.iteaconnect.org/TAA)
- ✦ National Science Education Standards (www.nsta.org/publications/nses.aspx)

Recommended Reading

- ✦ Timken: From Missouri to Mars - A Century of Leadership in Manufacturing (ISBN: 0875848877)
- ✦ Bicycling Science, by David Gordon Wilson (ISBN: 0262731541)
- ✦ Ball and Roller Bearings : Theory, Design and Application (ISBN: 0471984523)

Optional Writing Activity

- ✦ Write an essay or a paragraph describing three different machines that incorporate ball bearings or roller bearings. How does the use of the bearings improve the machine?

Extension to Older Students

- ✦ Older students work in teams to explore if other shapes of bearings might have advantages over the current ball or roller designs. Why or why not?

Getting Your Bearings

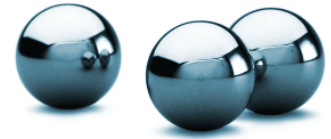

For Teachers: Teacher Resources

◆ Lesson Goal

Explore friction by demonstrating how ball and roller bearings work to reduce friction in machine design. Students compare the reduction in friction when moving a lid across a variety of surfaces when marbles are used to interact with the surface, learn about ball bearings and how the product evolved over time, and work in teams to explore friction.

◆ Lesson Objectives

- ✦ Students learn about friction.
- ✦ Students learn how incorporating ball bearings in a machine design can reduce friction.
- ✦ Students learn about many machines that incorporate ball or roller bearings.
- ✦ Students learn about teamwork.

◆ Materials

- Student Resource Sheet
- Student Worksheet
- One set of materials for each group of students:
 - Jar lid (from mayonnaise or similar container)
 - 25 identically sized marbles (larger than depth of lid used)
 - Book
 - Section of carpet or rug

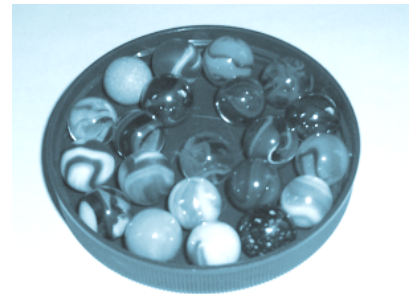

◆ Procedure

1. Show students the various Student Reference Sheets. These may be read in class or provided as reading material for the prior night's homework.
2. Divide students into groups of 3-4 students; provide one set of materials per group.
3. Ask students to feel the strength of the friction when trying to move the lid (open part down) of the jar across different surfaces: desk top, tile floor, piece of carpet.
4. Next, have students place enough marbles in the jar lid to almost fill the space with marbles (do not over fill so marbles cannot move freely). Use a book to turn the lid over, and have the student feel how much easier the lid moves across the same surfaces tried previously.
5. Try a variation where a book or other weight is placed on top of the lid (with and without marbles). Does the marble base allow for easier movement at different weights?
6. Ask students to suggest different machines that incorporate ball bearings or roller bearings, and to complete student worksheet.
7. Each student group presents their list of machines to the class and explains what the bearings do to improve the machine design and/or operation.

◆ Time Needed

One 45 minute session

Getting Your Bearings

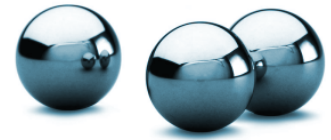

Student Resource: What is Friction? How do Ball Bearings Help?

◆ Friction

Friction is a term that describes how much resistance there is for two objects to move over another. The greater the friction, the more difficult it is for the two objects to move smoothly. With less friction, objects move easily and smoothly against one another. For example, a piece of rubber would have greater friction moving over a carpet than a smooth textbook would. In machines, parts rub against each other and increased friction can wear out parts faster.

◆ Ball Bearings

The term ball bearing sometimes means a bearing assembly which uses spherical bearings as the rolling elements. It also means an individual ball for a bearing assembly. Ball bearings are made of many different materials, including ceramics, metals, stainless steel, and other hybrid materials. They help reduce friction which keeps machines operating longer. They can also allow a machine to operate more quietly. Bearings were designed on a simple principle -- that objects roll more easily than they slide. When two objects slide against each other, like a book on a table, or a jar on a carpet, the friction between the surfaces works to slow the motion. If the objects could instead, roll over each other, then the amount of surface area that touch is limited and so the friction is reduced.

◆ Rolling Element Bearings

A rolling-element bearing is a bearing which carries a load by placing round elements between the two pieces. The relative motion of the pieces causes the round elements to roll (tumble) with little sliding. The illustration to the right is a patent design for caged radial ball bearings from U.S. Patent 6074099, and shows the balls encased between the round parts. One of the earliest and best-known rolling-element bearings are sets of logs which are laid on the ground with a large stone block on top. As the stone is pulled, the logs roll along the ground with little sliding friction. As each log comes out the back, it is moved to the front where the block then rolls on to it. You can imitate such a bearing by placing several pens or pencils on a table and placing your hand on top of them.

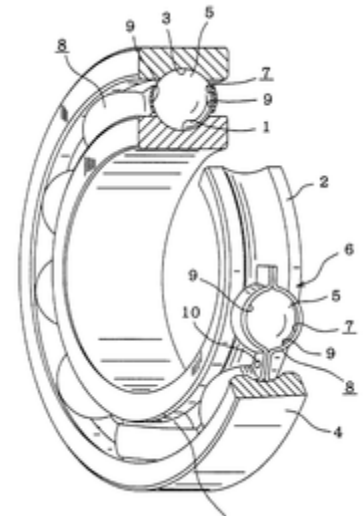

◆ Bicycles Without Ball Bearings? Roller Coasters Without Roller Bearings?

Bicycles are a great example of a machine that uses ball bearings to reduce friction. Ball bearings can be found in the pedals, in the front and rear hubs for the wheels, and the tube where the handlebars are attached. And skateboards and roller blades include ball bearings too! Beyond these examples, ball bearings are an important design element of oil drilling rigs, airplanes, and automobiles. Roller bearings are used in roller coasters!

Getting Your Bearings

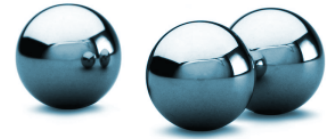

Student Resource: Ball Bearing History - Product Evolution

◆ History

An early example of a wooden ball bearing supporting a rotating table was retrieved from the remains of a Roman ship in Lake Nemi, Italy. The wreck was dated to 40 BC. Leonardo da Vinci is said to have described a type of ball bearing around the year 1500. One of the issues with ball bearings is that they can rub against each other, causing additional friction, but this can be prevented by enclosing the balls in a cage. The captured, or caged, ball bearing was originally described by Galileo in the 1600s.

◆ Innovation

Henry Timken, a 19th century visionary and innovator in carriage manufacturing, patented the tapered roller bearing in 1898. He envisioned a business built on solving a critical, age-old technical problem: friction, the force that impedes the motion of objects in contact with each other. "The man who could devise something that would reduce friction fundamentally," Timken observed, "would achieve something of real value to the world." The following year, he formed The Timken Company to produce his innovation.



Henry Timken

◆ Product Design and Improvement

Back when Henry began his development work, the dominant bearing was the plain, or "friction," bearing which had been in use with little change since ancient times. It was essentially a metal liner in the hole around a rotating shaft, with the main work of friction reduction depending on lubrication. Henry began experimenting with ball bearings but they failed rapidly from wear. He concluded that "roller" bearings held greater promise for vehicles, such as automobiles, because the weight of the load -- so much heavier than on a bicycle -- could be carried along the full length of the rollers, as opposed to the single point of contact on each ball in ball bearings. Henry tried straight rollers but settled on tapered, which permitted bearings to sustain forces from all directions. Since 1899, The Timken Company has produced more than six billion bearings and now makes bearings of many different types.



◆ Industries and Applications

Ball bearings are used in most industries, including transportation, aerospace, manufacturing, agriculture, and sports/entertainment. You'll find some examples of ball or roller bearings used in aircraft landing wheels, wind turbines, satellites, and rolling mills. Miniature bearings can be found in medical applications such as dental equipment.



Getting Your Bearings

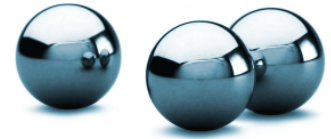

Student Worksheet:

Step One:

Read the Student Reference Sheets to learn about bearings and the history and evolution of ball and roller bearings.

Step Two:

Working in groups of 3-4 students, try moving the lid provided to you over several surfaces - book, desktop, floor, carpet.

Question:

1. What was the difference in friction moving the lid across different surfaces? Which surface exhibited the most friction? Why?

Step Three:

Place just enough marbles in the jar lid to almost fill the space with marbles (do not over fill so marbles cannot move freely). Use a book to turn the lid over, and now try moving the lid with the marble "balls" providing assistance with friction across the same surfaces tried previously.

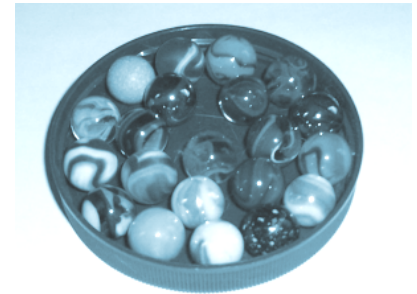

Questions:

3. What was the difference in the friction you experienced with the marbles rolling under the lid?

4. Did the marbles help on all surfaces? Only some? Which surface, if any, now exhibited the most friction? Why?

Step Four:

Try a variation where a book or other weight is placed on top of the lid (with and without marbles).

Questions:

5. Does the marble base allow for easier movement when weights are added?

6. Can you think of an application for a device like this? Who would need to move items with heavy weights? How would this help?

7. List three different machines that incorporate ball bearings or roller bearings.

1: _____ 2. _____ 3. _____

Getting Your Bearings

Getting Your Bearings

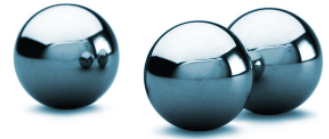

Optional Student Worksheet:

You are the Engineer! Problem Solving with Roller Bearings

◆ Instructions

You are the engineer! Work in a team and devise a plan using roller bearings to move one of your classroom desks, or a table, 10 feet using materials provided. Carpet may be used to protect floor from scratching. Challenge: limit the force you apply to make the desk or table move to what you can push using only your index finger. You may use up to 100 pencils, and as much tape as needed.

◆ Materials

One set of materials for each group of students:

- 100 Pencils
- tape
- rubber bands
- Section of carpet or rug

Step One:

Draw an illustration showing your planned solution below.

Step Two:

Try out your plan! See if you can move the desk using only your index finger.

Questions:

1. Did your planned design work? Why or why not?
2. What revisions did you have to make to your plan to make it a more effective solution?
3. Were you able to move the desk/table using only the force from one index finger?

Getting Your Bearings



For Teachers:

Alignment to Curriculum Frameworks

Note: All Lesson Plans in this series are aligned to the U.S. National Science Education Standards which were produced by the National Research Council and endorsed by the National Science Teachers Association, and if applicable, to the International Technology Education Association's Standards for Technological Literacy

◆ National Science Education Standards Grades K-4 (ages 4-9)

CONTENT STANDARD B: Physical Science

As a result of their activities, all students should develop an understanding of

- ✦ Properties of objects and materials
- ✦ Position and motion of objects

CONTENT STANDARD E: Science and Technology

As a result of activities, all students should develop

- ✦ Abilities of technological design

CONTENT STANDARD G: History and Nature of Science

As a result of activities, all students should develop understanding of

- ✦ Science as a human endeavor

◆ National Science Education Standards Grades 5-8 (ages 10-14)

CONTENT STANDARD B: Physical Science

As a result of their activities, all students should develop an understanding of

- ✦ Properties and changes of properties in matter
- ✦ Motions and forces
- ✦ Transfer of energy

CONTENT STANDARD E: Science and Technology

As a result of activities, all students should develop

- ✦ Abilities of technological design
- ✦ Understandings about science and technology

CONTENT STANDARD G: History and Nature of Science

As a result of activities, all students should develop understanding of

- ✦ Science as a human endeavor
- ✦ History of science

◆ National Science Education Standards Grades 9-12 (ages 14-18)

CONTENT STANDARD B: Physical Science

As a result of their activities, all students should develop understanding of

- ✦ Motions and forces
- ✦ Interactions of energy and matter

CONTENT STANDARD E: Science and Technology

As a result of activities, all students should develop

- ✦ Abilities of technological design
- ✦ Understandings about science and technology

CONTENT STANDARD F: Science in Personal and Social Perspectives

As a result of activities, all students should develop understanding of

- ✦ Science and technology in local, national, and global challenges

CONTENT STANDARD G: History and Nature of Science

As a result of activities, all students should develop understanding of

- ✦ Historical perspectives

Getting Your Bearings

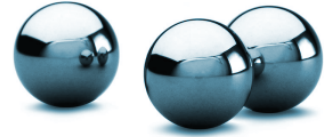

For Teachers: Alignment to Curriculum Frameworks (continued)

◆Standards for Technological Literacy - All Ages

Technology and Society

- ✦ Standard 6: Students will develop an understanding of the role of society in the development and use of technology.
- ✦ Standard 7: Students will develop an understanding of the influence of technology on history.

Design

- ✦ Standard 8: Students will develop an understanding of the attributes of design.
- ✦ Standard 9: Students will develop an understanding of engineering design.

Abilities for a Technological World

- ✦ Standard 13: Students will develop abilities to assess the impact of products and systems.